

Sd.Kfz. 184 FERDINAND

DRAGON

Premium EDITION



Technical drawings provided by MINORU IGARASHI. Project supervised by HIROHISA TAKADA.
Technical assistance provided by STEVEN VAN BEVEREN.
Thanks to TOM COCKLE and GARY EDMUNDSON as Technical Consultants.

KIT NO.6317

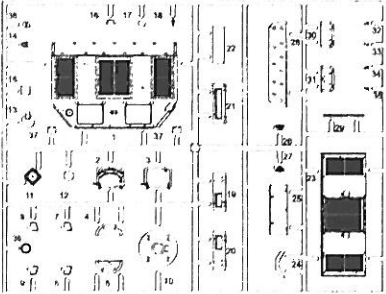
A/ 

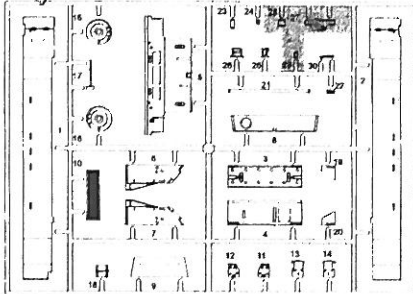
B/ 

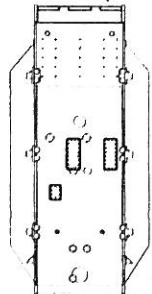
G/ 

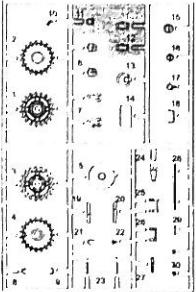
Ex2/ 

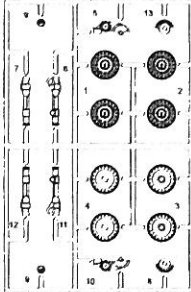
Fx3/ 

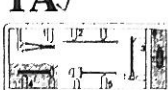
TA/ 

TB/ 

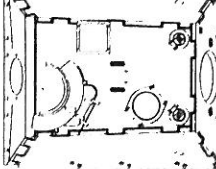
H/ 

TC/ 

S/ 

MD/ 

T/ 

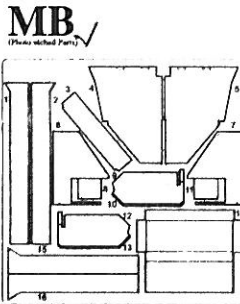
MB/ 

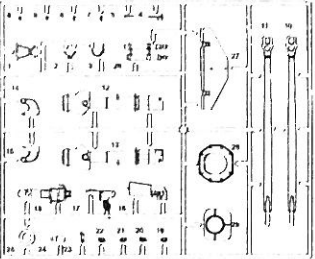
C/ 

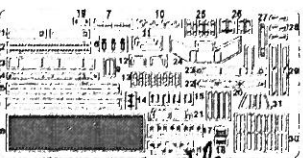
MA/ 

MC/ 

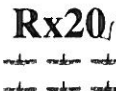
Rx20/ 

Lx20/ 

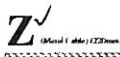
Z/ 

Oc Sample
DEC/28/06

© M&S B.V. 2004
Parts not for sale
Tanks, weapons, track & components
Plastic & no glue allowed
Paint not allowed

5

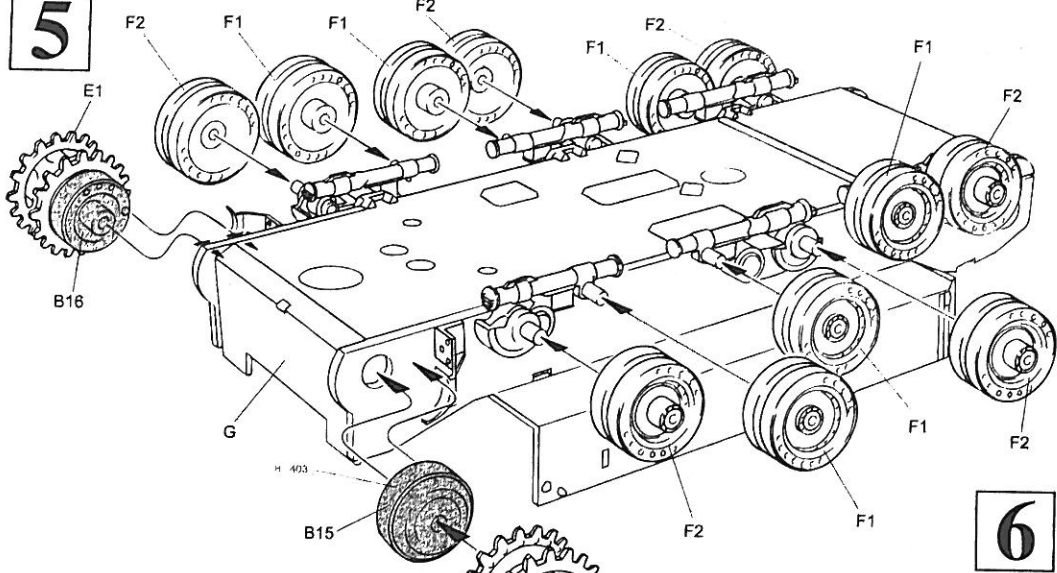

6

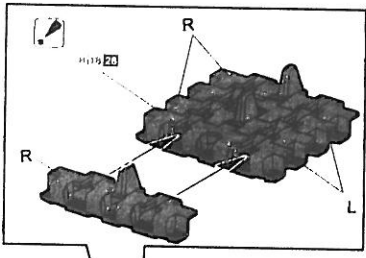
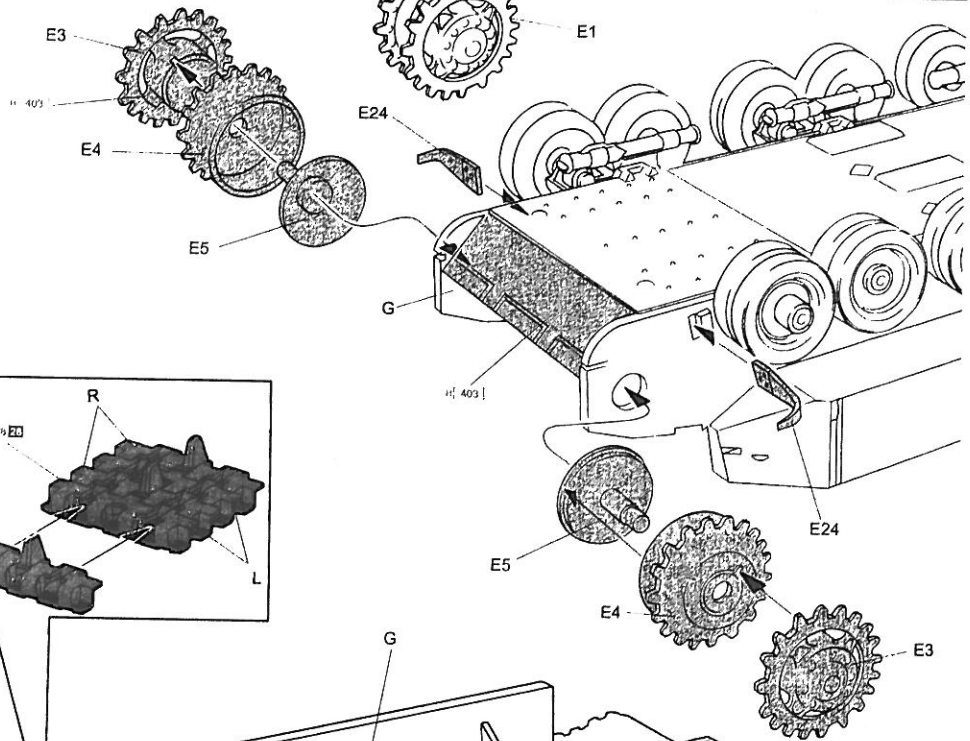

7

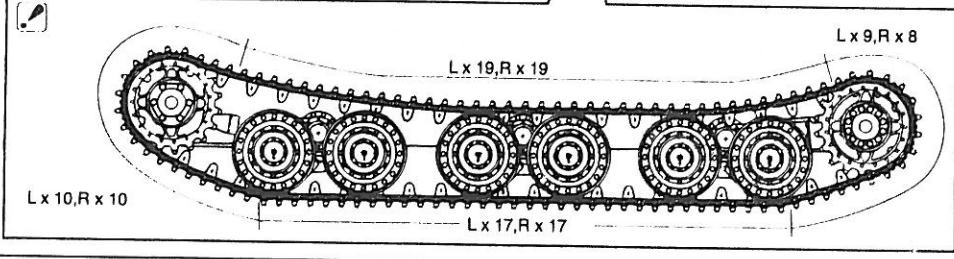
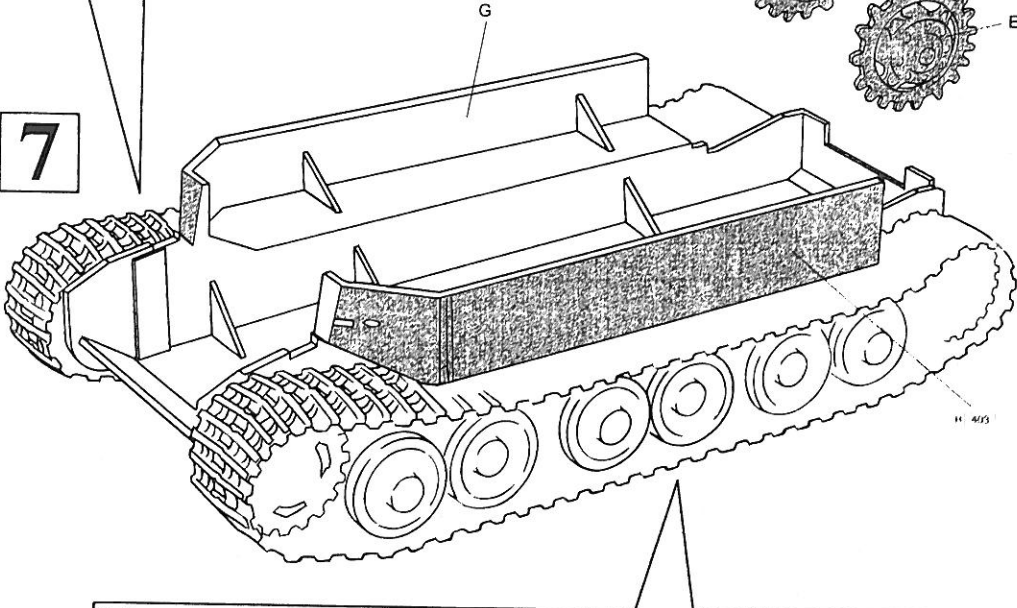

8

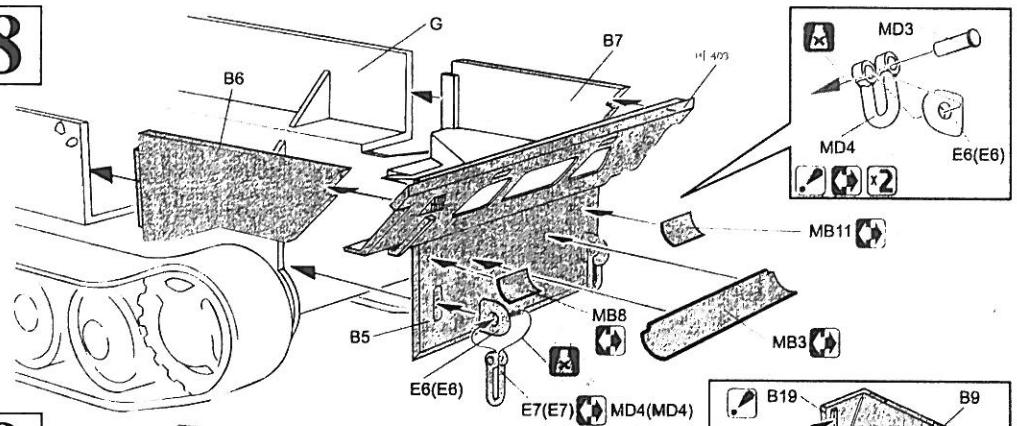

9

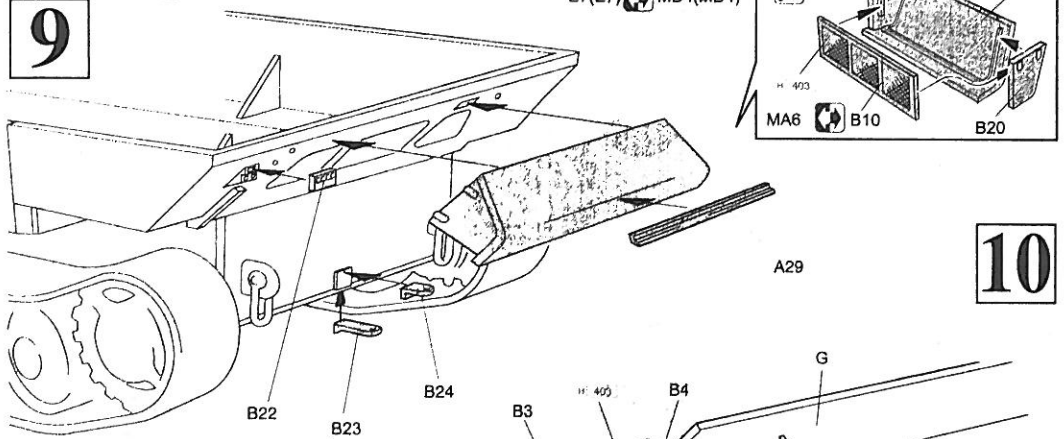

10

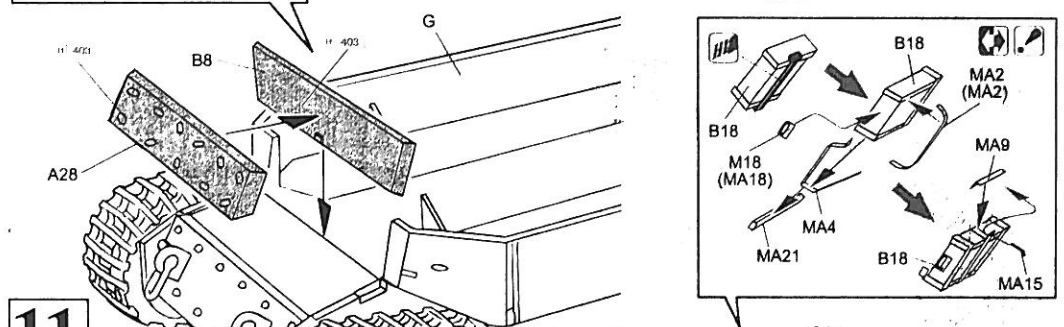
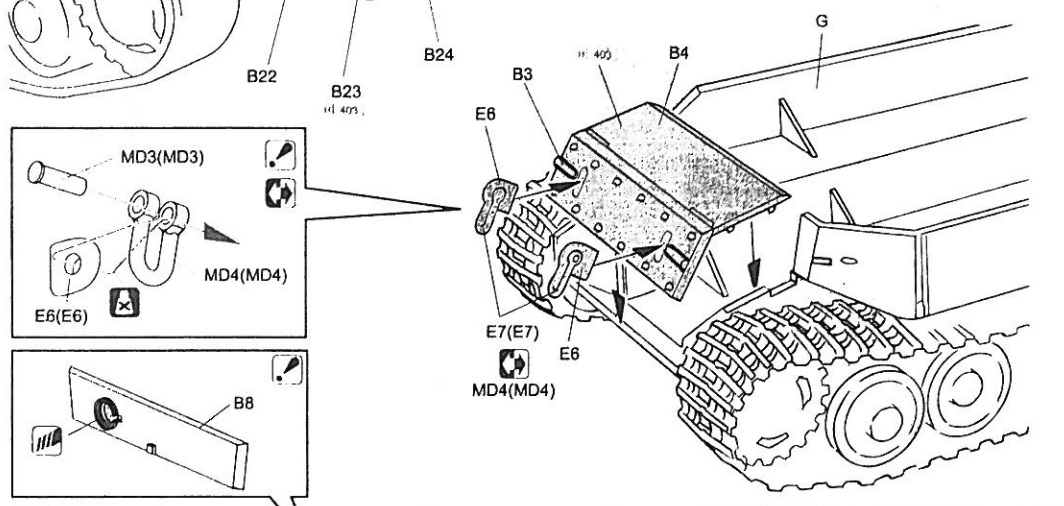

11

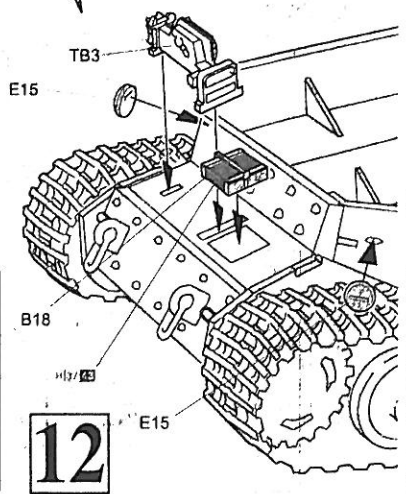
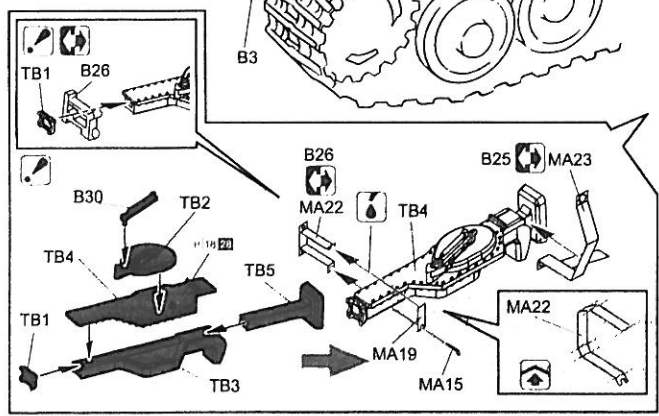

12

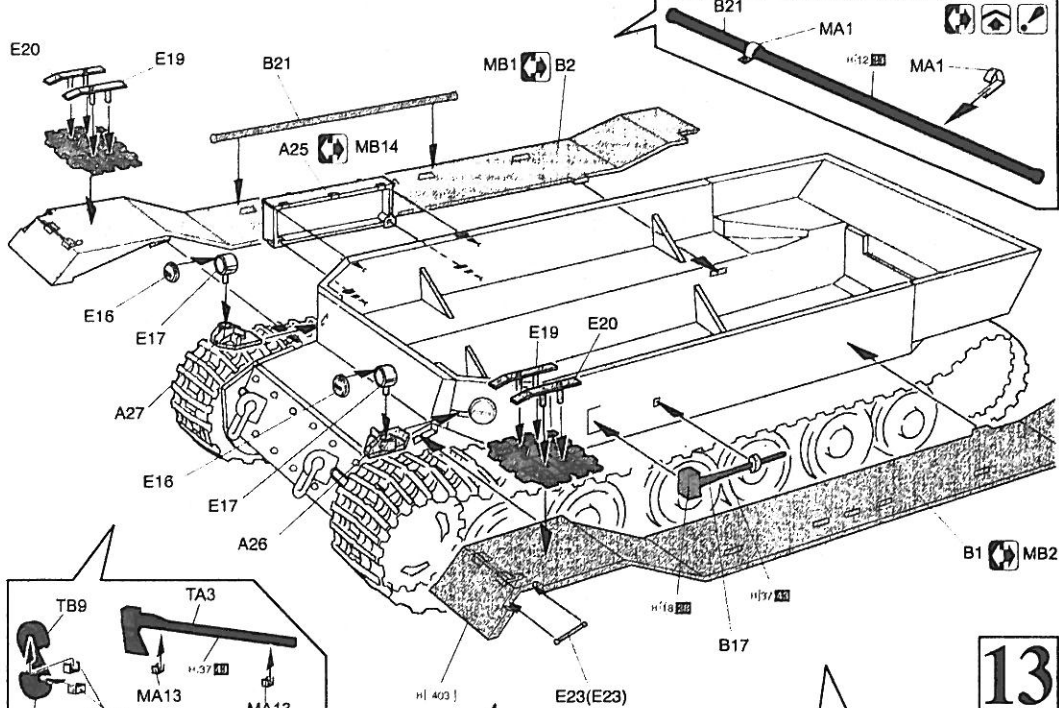

13

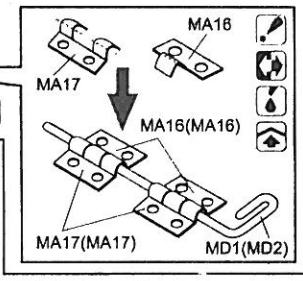
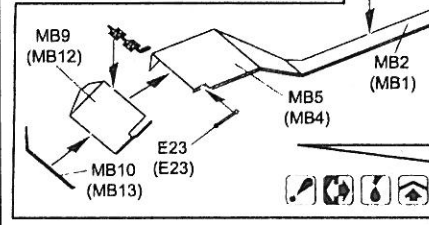
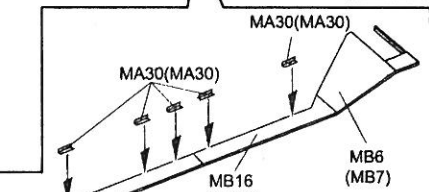
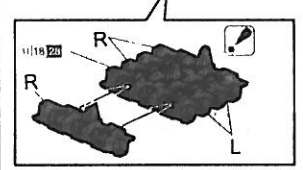
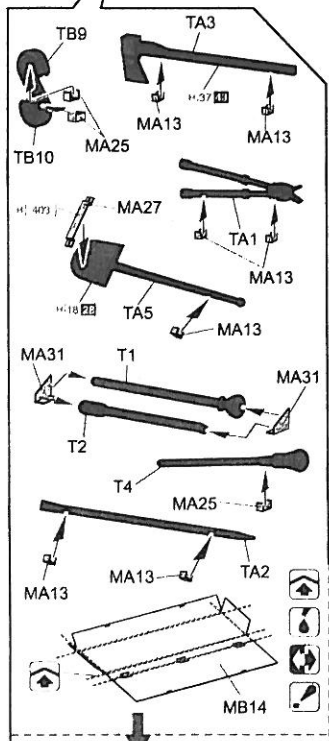

14

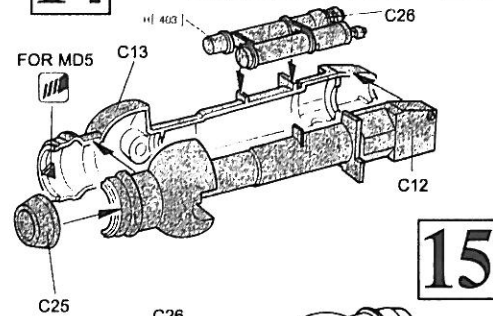
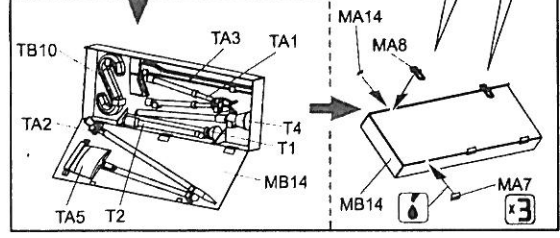

15

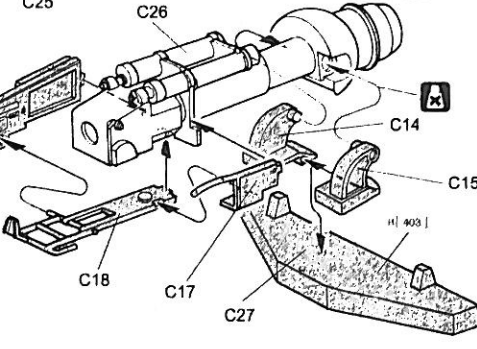
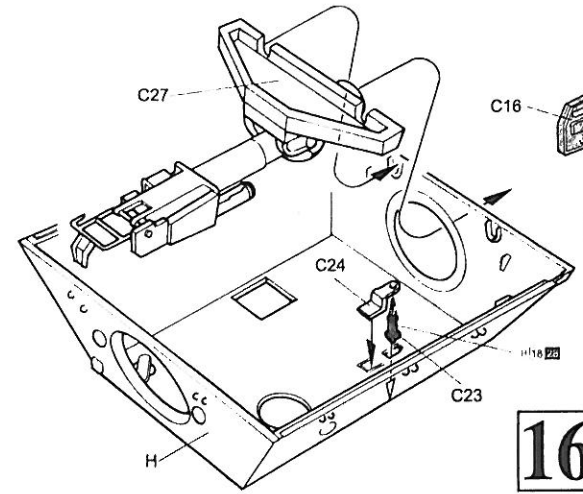

16

